

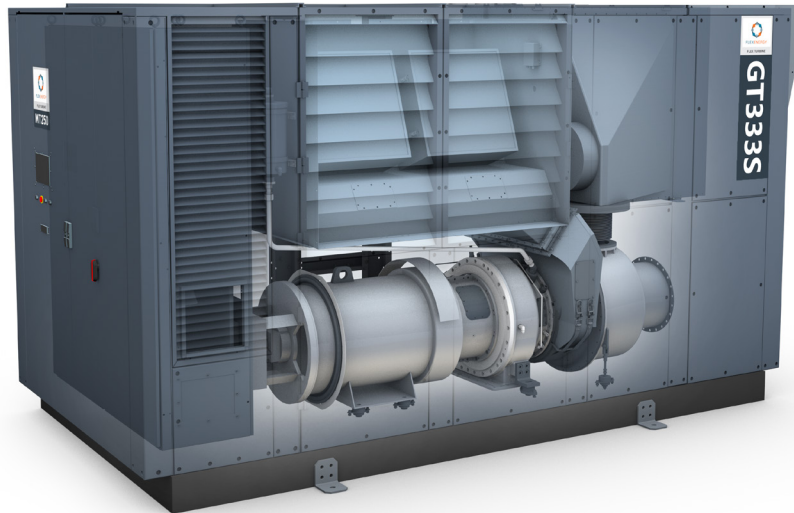

**HIGH EFFICIENCY GAS TURBINE GENERATOR
WITH ULTRA LOW EMISSIONS**

**333 kW
CONTINUOUS
ELECTRICAL POWER
WITH OPTIONAL
INTEGRATED HEAT
RECOVERY**



KEY FEATURES

- Fuel Flexibility: Seamless transition between Natural Gas & LPG
- California Air Resources Board (CARB) 2007 Certification
- Maximum total efficiency over 85%
- Synchronous generator ideal for managing site loads
- Grid-parallel, Grid-isolated, or Dual-mode operation
- Configurable with factory fitted heat recovery module, third party WHRUs or double effect absorption chillers
- Widest fuel tolerance of any small capacity gas turbine
- Only 8 hours of annual maintenance required

ELECTRICAL PERFORMANCE*

CHARACTERISTIC	SPECIFICATION
Electrical efficiency	33% LHV without gas booster
Electrical power	333 kW

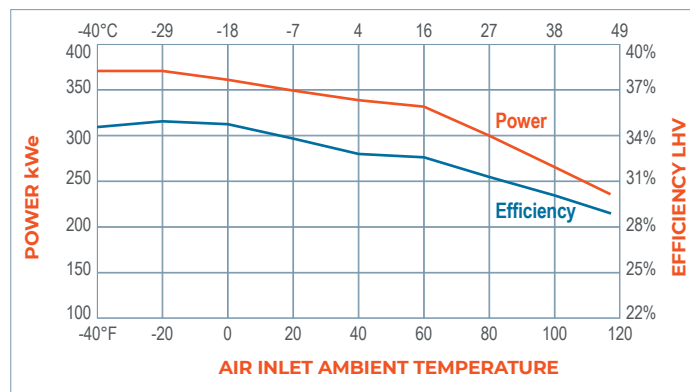

* At ISO Conditions (59°F [15°C], sea level, 60% RH); high pressure natural gas
 Electrical efficiency tolerance: +1/-2.5 pts
 Electrical power tolerance: +/-20kW
 Elevation derate of approximately 3.5% per 1000 ft (305 m)
 There is a 3 kW power reduction when utilizing waste heat recovery (cogen)

Rugged Gas Turbine

- Back-to-back rotating components
- Proven oil-lubricated bearings
- H₂S tolerance up to 6500 ppmv

Synchronous Generator

- Same technology utilities use to power the grid
- High load starting capability up to 125 hp DOL

Patented Recuperator

- Critical to high system efficiency
- Compact rugged design

Combined Heat and Power

- Controllable output level
- Integral heat recovery unit contained within turbine enclosure

Nominal Heat Rate (HHV)

11,552 Btu/kWh (12.2 MJ/kWh)
 w/o gas booster
 11,909 Btu/kWh (12.6 MJ/kWh)
 w/ gas booster

Nominal Heat Rate (LHV)

10,502 Btu/kWh (11.1 MJ/kWh)
 w/o gas booster
 10,827 Btu/kWh (11.4 MJ/kWh)
 w/ gas booster

Voltage

480 VAC / 400 VAC

Frequency

60 Hz / 50 Hz

Type of Service

3 phase, wye, 4 wire

Grid-isolated Regulation

± 0.50% nominal voltage
 (Steady State)
 ± 0.30 Hz nominal frequency

Transient Handling

± 10% nominal voltage max
 (Linear Loads)
 (Recovery within 5 sec)
 ± 5 Hz frequency max

GT333S GAS TURBINE CYCLE

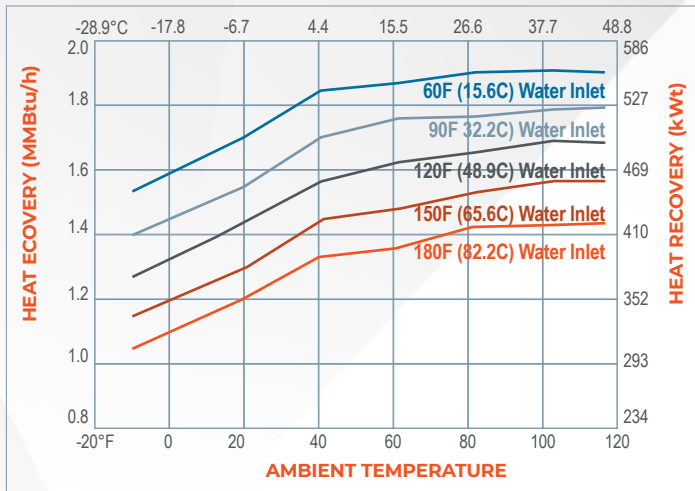

Note: Heat Recovery Unit (HRU) at 200 gpm (757 lpm) water flow, sea level, ± 15%

PHYSICAL SPECIFICATIONS

DIMENSIONS	WIDTH	LENGTH	HEIGHT	WEIGHT (est)
Indoor Unit	76.0 in	164.1 in	89.6 in	14,500 lb
	193.0 cm	416.9 cm	227.6 cm	6,577 kg
Outdoor Unit	76.0 in	165.0 in	155.6 in	14,500 lb
	193.0 cm	419.1 cm	395.2 cm	6,577 kg

SOUND LEVELS

CHARACTERISTIC	SPECIFICATION
Standard	62 dB(A) @ 10m
Low sound option (not available on all models)	57 dB(A) @ 10m

GENERATOR BRAKING RESISTOR

CHARACTERISTIC	SPECIFICATION
Dimensions (LxWxH)	43x63x31 (110x160x78 cm)
Weight	595 lb (270 kg)

EMISSIONS AT 100% LOAD*

CHARACTERISTIC	SPECIFICATION
NOx	<5 ppmv @ 15% O ₂
CO	<5 ppmv @ 15% O ₂
VOC	<5 ppmv @ 15% O ₂

* Pipeline natural gas only at ISO conditions

AMBIENT TEMPERATURE LIMIT

CHARACTERISTIC	SPECIFICATION
Standard	-10° to 115°F (-23° to 46°C)
Cold Weather Option*	-20° to 115°F (-29° to 46°C)

*Some configurations may require additional cold weather options

HEAT RECOVERY*

CHARACTERISTIC	SPECIFICATION
Exhaust temp (w/o HRU)	507°F (264°C)
Engine air flow	5.0 lb/s (2.3 kg/s) 3990 scfm (6400 Nm ³ /h)
Max available heat (direct exhaust)	1.9 MMBtu/h (556 kW)
Max water flow	225 gpm (852 lpm)
Max inlet water pressure	125 psig (862 kPa)
Max outlet water temp.	205°F (96°C)

* At ISO Conditions (59°F [15°C], sea level, 60% RH)
Available heat based on exhaust recovery down to 59°F (15°C)

FUEL REQUIREMENTS*

CHARACTERISTIC	SPECIFICATION
Fuel Consumption (LHV)	3.5 MMBtu/h (1025 kW)
Inlet pressure	-with gas booster 4" (100 mm) WC to 1 psig (6.9 kPa) -without gas booster 70 to 140 psig (483 to 965 kPa)
Min temperature**	35°F (2°C)
Max temp.	-with gas booster 115°F (46°C) -without gas booster 175°F (79°C)
333SW Model	325 to 600 WI Btu/ft ³ low caloric value gas, level 1 12.1 to 22.3 WI MJ/m ³
333ST Model	500 to 970 WI Btu/ft ³ low caloric value gas, level 2 18.6 to 36.1 WI MJ/m ³
333SM Model	800 to 1900 WI Btu/ft ³ medium / high caloric value gas 29.8 to 70.7 WI MJ/m ³

* Fuel consumption based at ISO conditions

** Or 18°F (10°C) dewpoint suppression, whichever is greater
WI - Wobbe Index Lower heating value (LHV)

GT333S GAS TURBINE CYCLE

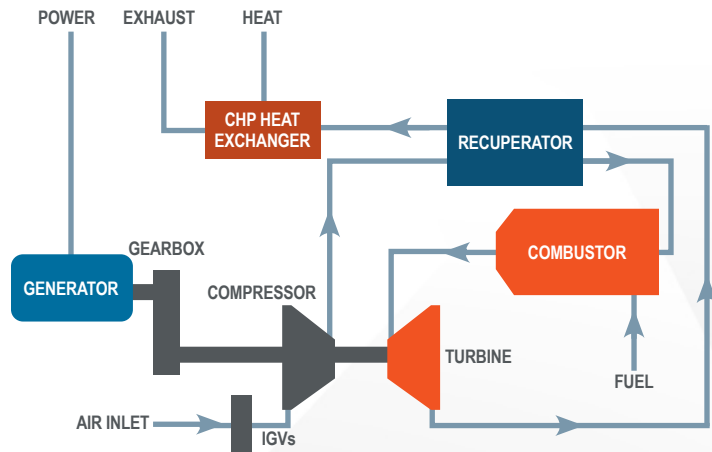

©2019 FlexEnergy Inc. and/or its affiliates ("FlexEnergy"). This document comprises a general overview of the products or services described herein. It is solely for informational purposes, does not represent a warranty of the information contained herein and is not to be construed as an offer to sell or solicitation to buy. Contact FlexEnergy for detailed product, design, and engineering information suitable to your specific applications. FlexEnergy reserves the right to modify its products and related product information at any time without prior notice.